

Vestas®

2 MW

GridStream™

V90-2.0 MW IEC IA/V100-2.0 MW IEC IIA

Wind. It means the world to us.™

Reliable, competitive and compliant. Re-engineering the **future of wind**

Proven platforms tailored for maximum delivery

The 2 MW GridStreamer™ V90-2.0 MW (IEC IA) and V100-2.0 MW (IEC IIA) are turbines conceived, built and optimised for the demands of the modern energy market. Their state-of-the-art gearbox, next-generation load management system and full scale converter-based power system provide greater energy production, superior grid compliance – maximising your return on investment.

Although our technology is cutting-edge, the Vestas 2 MW platform is the industry's most proven turbine family within the 2 MW category, with more than 7,800 installations worldwide. This means high reliability, low operational downtime and high performance. The new 2 MW GridStreamer™ family members are your low-risk choice for harnessing the financial potential of the wind.

Higher rated power boosts potential for profits

The turbines reach rated power of 2.0 MW with a 90 m rotor in IEC IA sites and with a 100 m rotor in IEC IIA and IIIA sites, leading to higher energy production and greater profitability.

The two new 2 MW GridStreamer™ turbines have been designed with higher rated power, and lower component stress for increased reliability. The upgraded technology allows us to site turbines with larger rotor diameters in locations with higher wind speeds.

Global grid compliance safeguards your investment

The new 2 MW GridStreamer™ turbines are designed for optimum compliance with grid standards worldwide. The Vestas advanced grid compliance system provides active and reactive power regulation, fast response to changes in frequency and fault ride-through capabilities to support grid levels and stability in the event of grid fluctuations.

Investing in a 2 MW GridStreamer™ means investing in turbines that can adapt to even the most challenging grid codes.

Designed for ultimate business case certainty

With a market-leading track record, best-ever performance, improved grid compliance and the possibility of energy-based service agreements, the new 2 MW GridStreamer™ turbines are in a class of their own – ensuring the best business case certainty for our customers.

Wind. It means the world to us.™
Wind is all we do. We are relentlessly committed to the success of wind as a source of energy for the world, providing everything you need to succeed in your wind power ambitions.



Energise your investment

For maximum yield from IEC IA and IEC IIA locations, the V90-2.0 MW GridStreamer™ (IEC IA) and V100-2.0 MW GridStreamer™ (IEC IIA) turbines are your safest choices for reliability, versatility, and low cost of energy.

Fig 1: The new 2 MW GridStreamer™ turbines are designed to operate with outstanding efficiency across all wind classes, from high to low wind speeds.

Fig 2: The model draws a picture of the Annual Energy Production (AEP) across different wind speeds illustrating optimum output.

More flexibility

Worldwide grid support

- for comprehensive compatibility

Easy-access design from tower to nacelle

- for improved ergonomics

Technologically versatile

- for operation from -30°C to 40°C
- Certified for installation up to 2,000m.
- Installation above 2,000m depends on site specific conditions

Lower energy costs

Optimised state-of-the-art gearbox design

- for increased reliability and energy output

Innovativae CoolerTop® system

- for more efficient operation

Substation cost savings

- by making STATCOMs and capacitor bank unnecessary

Safe investment

Proven, reliable equipment

- for your peace of mind

Built to latest design standard IEC 61400-1 edition 3

- for a more robust turbine

Type certificate according to latest standard IEC 61400-22

- for industry assurance

Enhanced control strategy

- protecting your turbine in case of extreme wind and turbulence beyond the IEC definitions

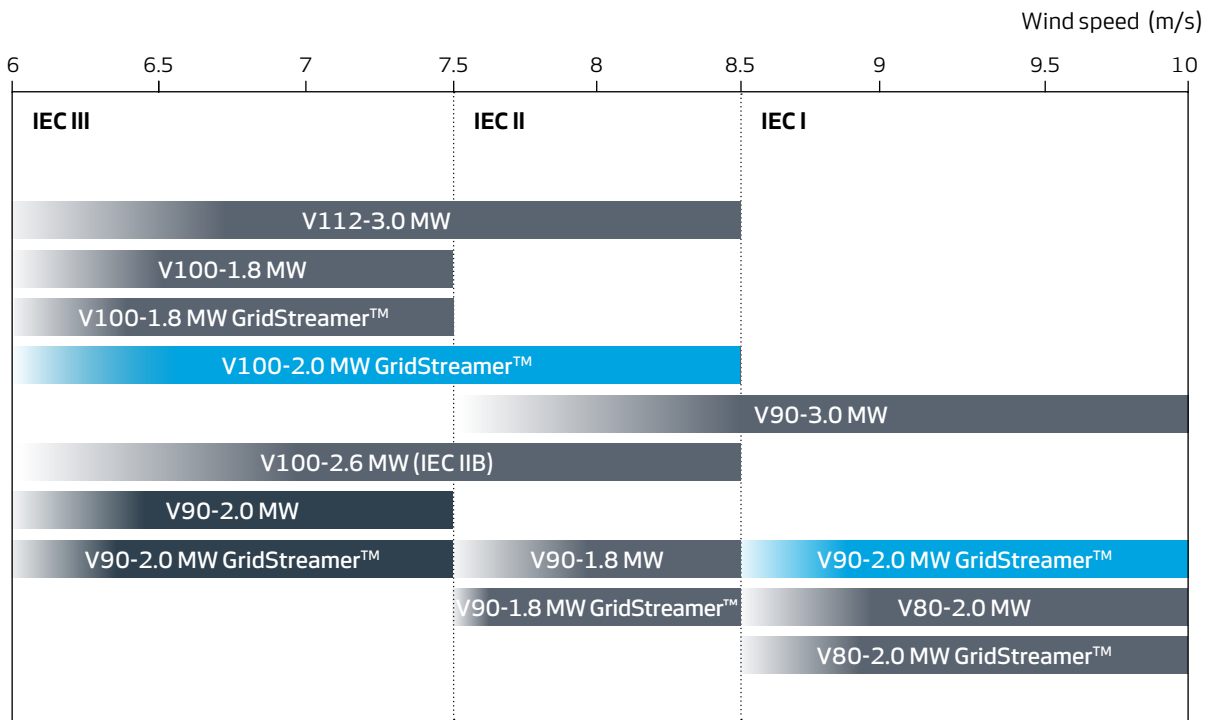

Fig 1. Overview of Vestas wind turbines operating in the various wind classes

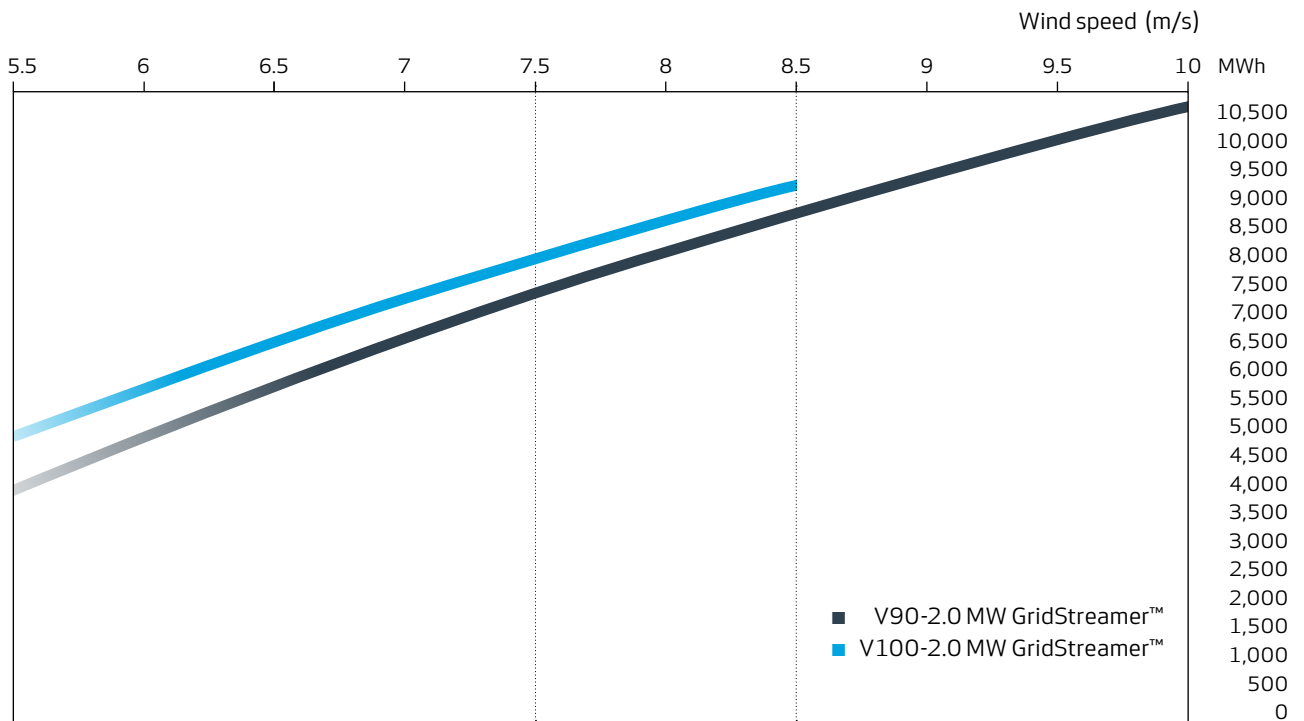

Fig 2. Annual Energy Production (AEP) for the V90-2.0 MW GridStreamer™ (IEC IA) and V100-2.0 MW GridStreamer™ (IEC IIA)

Optimised gearbox design ensures best ever performance

Perfecting technology for customer confidence

As a critical component in any turbine, we have concentrated much of our design work on the gearbox. Our aims are commercially driven: To increase performance, further improve reliability and reduce maintenance costs, providing a rock-solid investment case.

To achieve these goals we have focused on optimised and streamlined gearbox technology, resulting in a piece of equipment which can transfer more torque without increasing the dimensions and has undergone a rigorous testing programme.

The turbine delivers greater power output and the full scale converter offers superior grid compliance. Furthermore, the turbine comes with a next-generation load management system – all adding up to set new benchmarks for reliability, efficiency and competitive cost of energy in the 2 MW class.

Low weight equipment, same great performance

The optimised gearbox benefits from integrated torque arms and a lubrication unit, reducing the complexity of the equipment and cutting down servicing costs. Crucially, although weight has been reduced, performance has not been compromised.

Improved up-tower repair options, for more efficient maintenance of high and intermediate-speed stages, further reduce service time. Access space from the tower into the nacelle has been increased by 60% for further ease and speed of servicing.

Integrated lubrication unit (one electrical pump)

– A fully integrated system with fewer components and only one electrical pump.

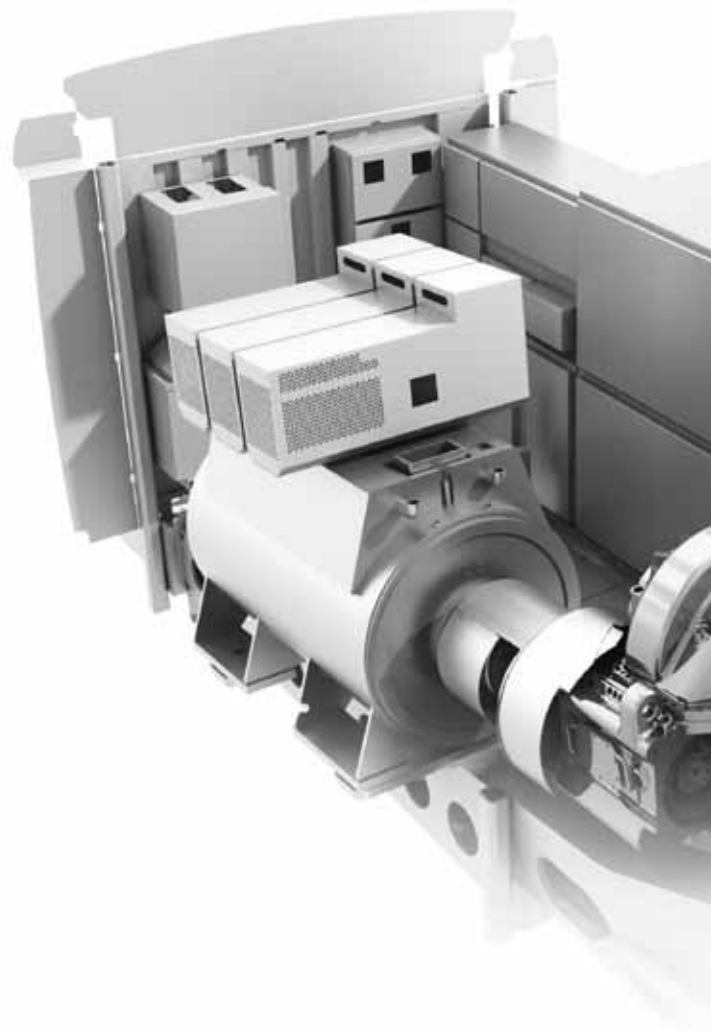



Access space from the tower into the nacelle has been increased by 60% for more efficient maintenance of high and intermediate-speed stages.

Significantly improved nacelle access

- The space in the service tunnel has been increased.
- The heating elements are now placed at the rotor side of the gearbox.

Integrated torque arms

- Reduce the complexity of the equipment.



Comprehensive testing for dependable performance

In wind power, greater reliability means greater profitability. That's why we have put the new 2 MW GridStreamer™ through our most extensive verification and testing program – a rigorous procedure which ensures that you benefit from the most advanced and reliable technology.

Our Vestas Test Centre in Denmark is the epicentre of our ceaseless drive towards reliability. Within these facilities, we have carried out exhaustive design verification for the new 2 MW GridStreamer™. All major components have been tested for functionality and performance according to the design and specifications.

Our gearboxes then undergo Qualitative Reliability Tests to verify robustness against severe use conditions, being exposed to stresses and strains beyond any encountered during the turbine's lifetime. Units are then tested in the field to ensure performance characteristics in real world environment, including system integration testing with detailed measurements taken of variables including stress, temperature, oil pressures, vibrations and noise – all verified against design calculations and simulations.

Finally, units undergo accelerated lifetime tests – the final stage in ensuring that our cutting-edge designs have evolved into truly state-of-the-art, dependable equipment.

The **technology** you need – wherever you need it

Maximising compliance – all around the world

With a Vestas permanent magnet generator and a full scale converter, the 2 MW GridStreamer™ complies with even the most challenging grid requirements of the modern energy market.

Protecting your investment by safeguarding the technology is important to us. In the event of lost grid connection, excess power is converted into heat in resistors, sparing the drive train components any unnecessary loads. The power system delivers a power factor range of +/-0.9 at full power and is capable of a Low Voltage Ride-Through down to 0 volts for 0.5 seconds.

Just like the wind, the world energy market moves fast. The 2 MW GridStreamer™ allows you to respond rapidly to new and changing grid requirements with the added confidence provided by proven Vestas technology.

Saving you costs at every turn

Our 2 MW GridStreamer™ turbine further lowers your cost of energy through lower foundation, erection and grid connection costs – including reduced substation costs through full grid compliance at the turbine level. Less substation equipment and fewer STATCOMs means not only less equipment to purchase, but also less to install and maintain.

EXCELLENT GRID SUPPORT

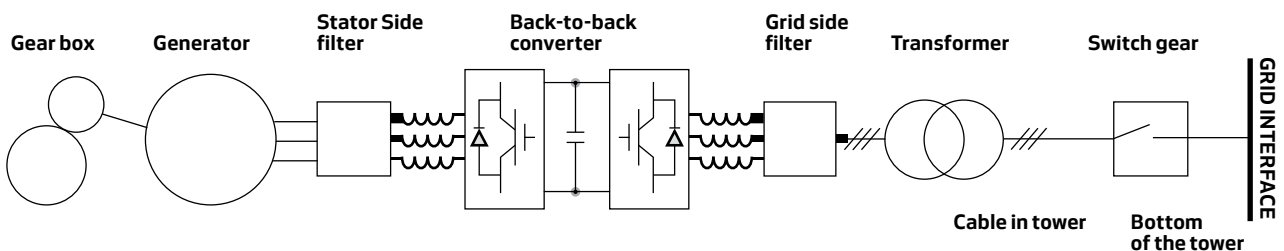

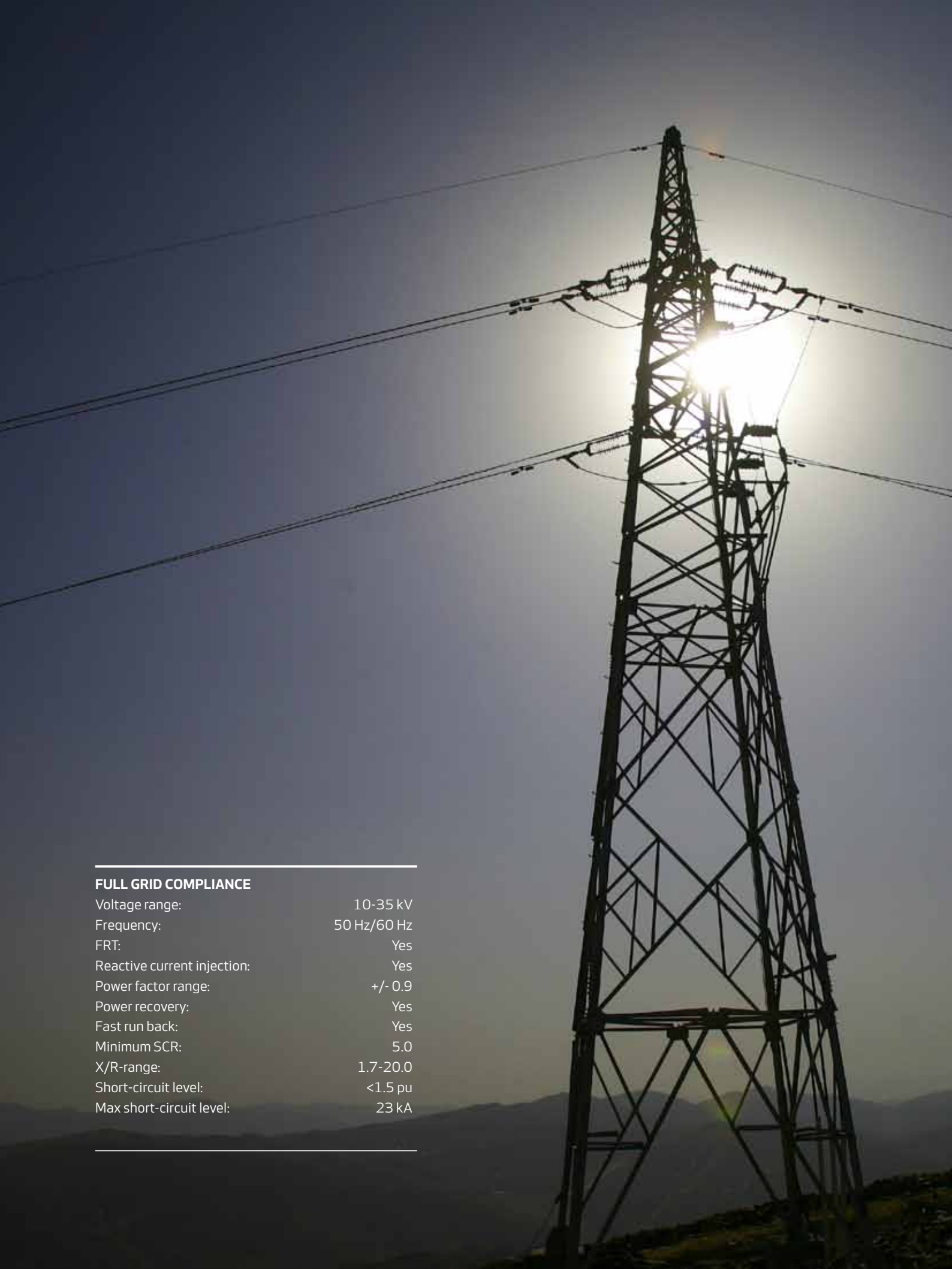

FULL GRID COMPLIANCE

Voltage range:	10-35 kV
Frequency:	50 Hz/60 Hz
FRT:	Yes
Reactive current injection:	Yes
Power factor range:	+/- 0.9
Power recovery:	Yes
Fast run back:	Yes
Minimum SCR:	5.0
X/R-range:	1.7-20.0
Short-circuit level:	<1.5 pu
Max short-circuit level:	23 kA

Hi-tech engineering designed for greater **profitability**

Cooling the cost of temperature regulation

Heat control is an important feature for running your wind turbine smoothly and efficiently. Our CoolerTop® technology, which comes as standard with all our 2 MW GridStreamer™ turbines, helps moderate optimum operating temperatures within the turbine, even at high ambient temperatures and altitudes. This ability opens up whole new areas of land once considered unsuitable for wind turbines – even ones near populated areas – due to its minimal noise impact. The absence of electrical components and moving parts means it needs little servicing – assuring you of ultimate efficiency and yet lower running costs.

Furthermore, our 2 MW GridStreamer™ can operate at anything between -30°C and 40°C.

Scaling new heights of adaptability

The upgraded turbines have been certified for high-altitude operation up to 2,000 meters and may be installed at higher altitudes, depending on site-specific conditions.

Lowering maintenance costs for greater profitability

Maintenance and repairs can now be performed faster and cheaper up-tower, and with greater technical ease, thanks to our updated ergonomic nacelle design with increased access and working environment.

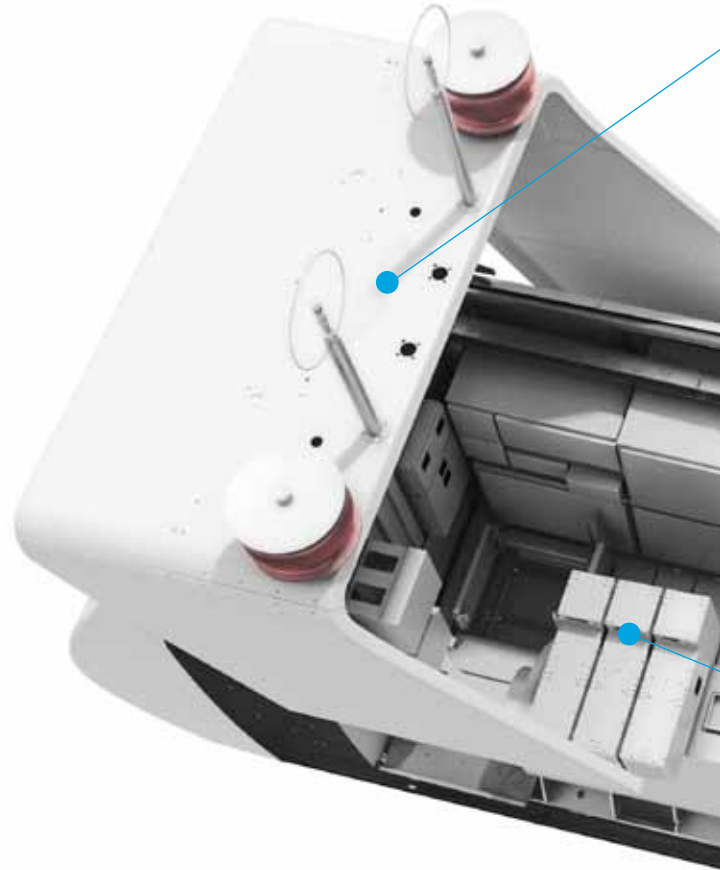

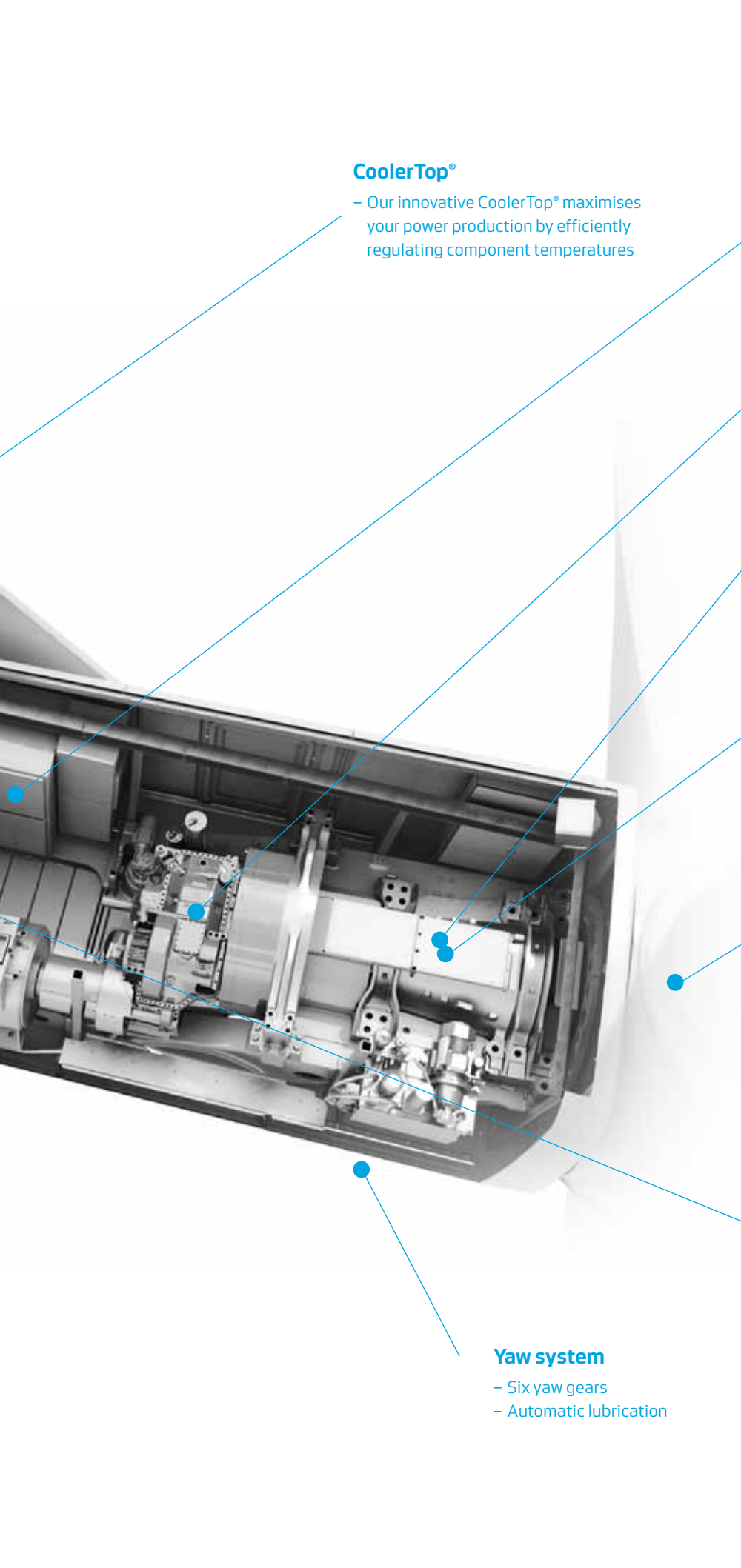

CoolerTop®

- Our innovative CoolerTop® maximises your power production by efficiently regulating component temperatures

Full scale converter

- Modular layout for improved serviceability
- Internal crane for module replacement
- Water-cooled power components

Gearbox

- Reliable gearbox design based on most proven technology

Main shaft

- Forged for robustness

Main-bearing housing

- One moulded piece
- Stronger construction to absorb higher loads from rotor
- All rotating parts shielded

Blades

- Market-leading aerodynamic design
- V90-2.0 MW GridStreamer™ (IEC IA) and V100-2.0 MW GridStreamer™ (IEC IIA) 44m/49m blades made from glass-fibre and carbon fibre in epoxy resin - combining proven and innovative technologies

Permanent magnet generator

- Simple, efficient power system with excellent fault ride-through capacity
- No slip rings or brushes for less maintenance
- Internal ventilation and water jacket cooling
- Vacuum-impregnated windings
- High-capacity bearings (ceramic)

Yaw system

- Six yaw gears
- Automatic lubrication



+43,000

We have delivered more than
43,000 turbines worldwide.

Safeguarding your investment, powering **your profits**

Technology you can rely on

With the introduction of the new more powerful and versatile 2 MW GridStreamer™ turbines, customers can confidently deploy a modular fleet of efficient and fully grid compliant 2 MW turbines for optimal performance across all wind classes and site conditions. Our engineers have combined state-of-the-art components with our existing market-leading technology, merging proven reliability with the ultimate in grid performance and compliance.

Vestas' 2 MW platform is the industry's most proven platform within its 2 MW class, with thousands of turbines installed over the last decade. Operational data gathered from more than 18,000 turbines globally is used to hone the performance of every Vestas turbine.

We incorporate permanent magnet generators – engineered for strength, serviceability and productivity – in all our 2 MW GridStreamer™ turbines, enabling the widest possible operational wind speed range. And by sharing the same tried-and-trusted generator, converter, transformer and switchgear designs as our V112-3.0 MW, we further increase reliability and business case certainty.

Track record reinforces reliability

Many of the features in the 2 MW GridStreamer™ range – including the pitch, yaw and control systems – are common throughout our global 2 MW range. Our real-time 'in the field' testing means you can be as confident as we are in the strength of our equipment. We know that by minimising downtime we can maximise the return on your investment.

We have the evidence to back up our high aspirations. Our entire 2 MW GridStreamer™ turbine range is designed and certified according to IEC 61400-1 Edition 3, and type certified according to IEC 61400-22 – further securing your assets.

Giving you the tools to take charge of **your investment**

High quality information for high quality decision-making

Our cutting-edge Supervisory Control and Data Acquisition (SCADA) system will help you operate your wind power plant for maximum efficiency. Just as you would expect for a conventional power plant, Vestas' SCADA system features comprehensive monitoring and management functions for controlling your 2 MW GridStreamer turbine and moderating its output. This means that you can adjust production levels, record performance and produce detailed reports from anywhere in the world.

Monitoring minimises downtime – and lost revenue

In the wind farm industry, knowledge is power. For commercial success you need productivity to be high and maintenance costs to be low. Fortunately, by working with Vestas on your wind power project, you'll receive a predictive maintenance system along with 24/7 performance reporting.

The Vestas Condition Monitoring System measures signals such as vibration and temperature, and charts the progress of any damage. By giving you early alerts for crucial component failures and future maintenance needs, you can keep repair costs low and uptime high – the perfect formula for a reliable investment.

Guaranteeing your commercial success

No one knows wind like we do. We understand that making the most of your investment means capturing the maximum amount of wind energy for converting into power output. Our Active Output Management® (AOM) system, based on more than three decades of industry experience, provides the final assurance investors seek.

AOM incorporates detailed plans for servicing, online monitoring, equipment optimisation and troubleshooting. Best of all, it also includes a competitive insurance scheme tailored around your needs. As a customer, you may opt to be risk-tolerant, or, for complete peace of mind, you might choose a full-availability guarantee, receiving compensation if the turbine fails to meet agreed availability targets.

AOM 5000 – our ultimate insurance package

This package not only aims to minimise lost production – it reimburses you for any shortfall. It means we shoulder the burden for aligning servicing and maintenance for periods of low wind activity, keeping output as high as possible.

Service contracts cover periods up to ten years and provide energy-based guarantees of up to 97%, backed up by contractual liquidated damages and bonus clauses. The confidence bestowed on you by this arrangement is a reflection of the faith we place in our technology.



Facts and figures

V90-2.0 MW

GridStreamer™ (IEC IA)

POWER REGULATION

pitch regulated with variable speed

OPERATING DATA

Rated power	2,000 kW
Cut-in wind speed	4.0 m/s
Rated wind speed	13.5 m/s
Cut-out wind speed	25 m/s
Recut-in wind speed	23 m/s
Wind class	IEC IA
Operating temperature range	standard turbine: -20°C to 40°C low temperature turbine: -30°C to 40°C

SOUND POWER MODES

Mode 0: Max sound power level:	105.5 dB(A)
Mode 1: Max sound power level:	105.5 dB(A)*
Mode 2: Max sound power level:	103 dB(A)
*) low noise at low wind	

ROTOR

Rotor diameter	90 m
Swept area	6,362 m ²
Nominal revolution	16.9 rpm
Air brake	full blade feathering with 3 pitch cylinders

ELECTRICAL

Frequency	50/60 Hz
Generator type	permanent magnet generator
Converter	full scale converter

GEARBOX

Type one planetary stage and two helical stages

TOWER

Type tubular steel tower
Hub heights 80 m (IEC IA), 95 m (IEC IIA),
105 m and 1.25 m (IEC IIIA and DIBt 2)

BLADE DIMENSIONS

Length 44 m
Max. chord 3.5 m

NACELLE DIMENSIONS

Height for transport 4 m
Height installed (incl. CoolerTop®) 5.4 m
Length 10.4 m
Width 3.4 m

HUB DIMENSIONS

Max. diameter 3.3 m
Max. width 4 m
Length 4.2 m

Max. weight per unit for transportation 70 metric tonnes

POWER CURVE FOR V90-2.0 MW GridStreamer™ (IEC IA)

Noise reduced sound power modes are available

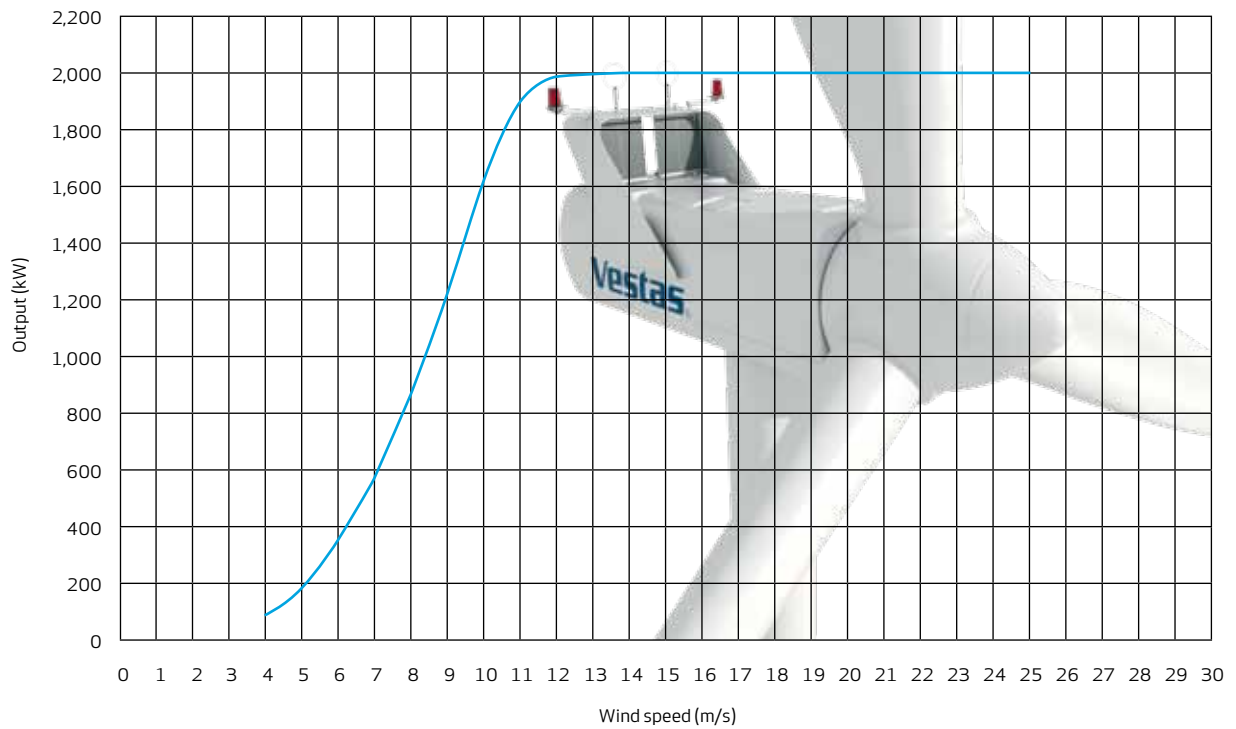

Facts and figures

V100-2.0 MW

GridStreamer™ (IEC IIA)

POWER REGULATION

pitch regulated with variable speed

OPERATING DATA

Rated power	2,000 kW
Cut-in wind speed	3.0 m/s
Rated wind speed	12,5 m/s
Cut-out wind speed	20 m/s
Recut-in wind speed	18 m/s
Wind class	IEC IIA
Operating temperature range	standard turbine: -20°C to 40°C low temperature turbine: -30°C to 40°C

SOUND POWER MODES

Mode 0: Max sound power level:	105.5 dB(A)
Mode 1: Max sound power level:	105.5 dB(A)*
Mode 2: Max sound power level:	103 dB(A)
*) low noise at low wind	

ROTOR

Rotor diameter	100 m
Swept area	7,854 m ²
Nominal revolution	14.9 rpm
Air brake	full blade feathering with 3 pitch cylinders

ELECTRICAL

Frequency	50/60 Hz
Generator type	permanent magnet generator
Converter	full scale converter

GEARBOX

Type one planetary stage and two helical stages

TOWER

Type tubular steel tower
Hub heights 80 m and 95 m (IEC IIA),
1.25 m (IEC IIIA and DIBt 2)

BLADE DIMENSIONS

Length 49 m
Max. chord 3.9 m

NACELLE DIMENSIONS

Height for transport 4 m
Height installed (incl. CoolerTop®) 5.4 m
Length 10.4 m
Width 3.4 m

HUB DIMENSIONS

Max. diameter 3.3 m
Max. width 4 m
Length 4.2 m

Max. weight per unit for transportation 70 metric tonnes

POWER CURVE FOR V100-2.0 MW GridStreamer™ (IEC IIA)

Noise reduced sound power modes are available

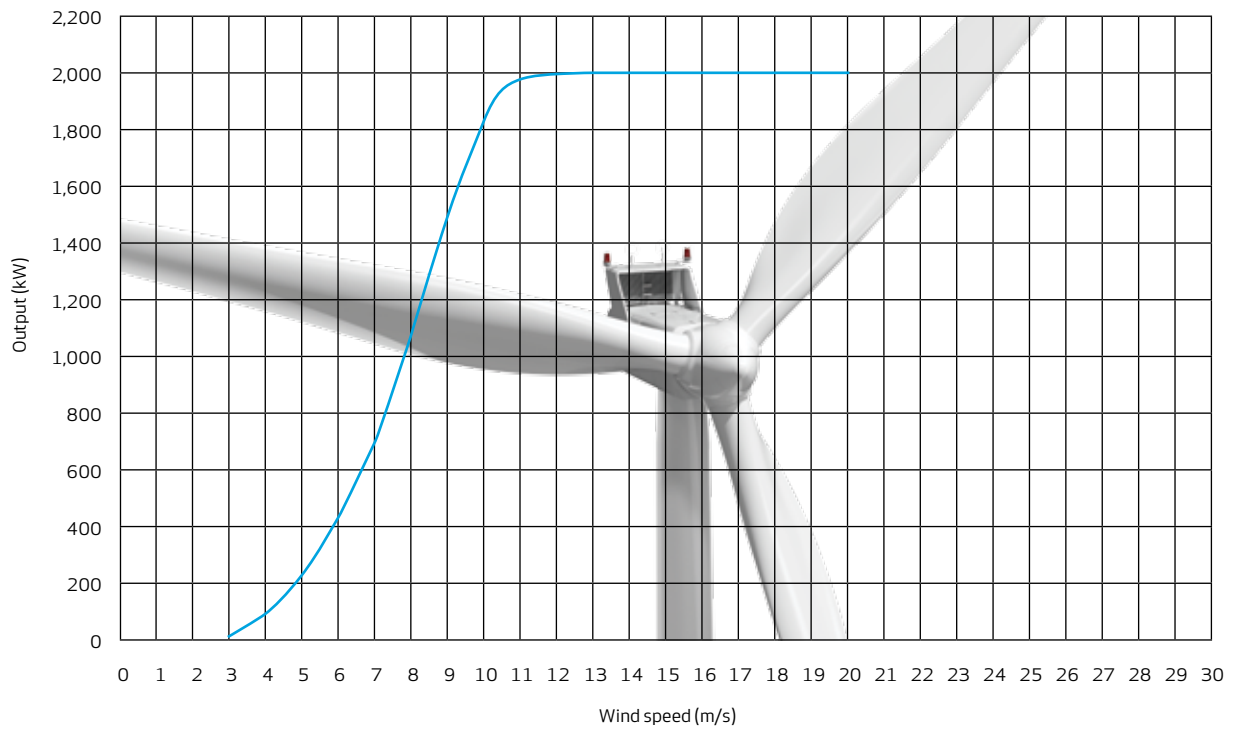

Vestas Wind Systems A/S
Alsvej 21 . 8940 Randers SV . Denmark
Tel: +45 9730 0000 . Fax: +45 9730 0001
vestas@vestas.com . vestas.com

©Vestas 2011

This document was created by Vestas Wind Systems A/S and contains copyrighted material, trademarks and other proprietary information. All rights reserved. No part of the document may be reproduced or copied in any form or by any means such as graphic, electronic or mechanical, including photocopying, taping or information storage and retrieval systems, without the prior written permission of Vestas Wind Systems A/S. All specifications are for information only and are subject to change without notice. Vestas does not make any representations or extend any warranties, expressed or implied, as to the adequacy or accuracy of this information.